

- **Stainless Steel Construction**
- **Equipped Standard with Ketan K50 Label Applicator**
- **Apply Labels to Various Types of Smaller or Unstable Round Products**



- **Excellent Label Placement Accuracy**
- **Apply Labels Up to 4" In Width**
- **Perfect for Labeling Ampoules!**
- **Automatic Magazine In Feed & Discharge Collection or Unit Can Be Hand Fed with Discharge Bucket**



Standard Features & Specifications

- Label dispense speed up to 30 meters/min (Up to 100 BPM dependent on label length)
- Programmable Controller with LCD, product memory, counter, password protection & more
- Equipped standard with Ketan K 50 stepper driven label applicator
- Capable of handling products up to 5" in length or height
- Capable of applying label widths up to 4"
- Equipped standard with discharge platform
- Stainless steel Construction
- Equipped with leveling feet & casters (Unit can be set in place or completely mobile)
- Turn handle adjust for applicator & wrap belt height– easily adapts to various sized diameter products
- UW60 Standard unit comes as hand fed system with discharge platform
- Equipped standard with missing label on web detection

Electrical Requirements

115 or 220 VAC 50-60Hz (10 amps)

Weight

370 lbs (185 kg)

Environment

32° to 115° F (0° to 46° C)

Options

- Ink jet coder integration for applying lot or expiries directly onto the label
- Automatic in feed & discharge magazines
- Hand fed in feed wheel with discharge bucket
- Clear label sensor
- Low label sensor with three stage light beacon
- Custom integration available– ask Ketan representative for details
- Label verification systems available– ask Ketan representative for details



Apply labels to ampoules or other unstable round products

Ketan Automated Equipment, Inc. offers a wide range of coding, labeling & product handling systems for identification of products in multiple types of industries. As part of the continuing process of development Ketan reserves the right to alter the specifications and other details of its products without notice. Please ask Ketan for the latest details

Ketan Automated Equipment, Inc.

1140 E Locust Street, Suite 100, Ontario, CA 91761
Phone (909) 930-0780 Fax (909) 930-0945

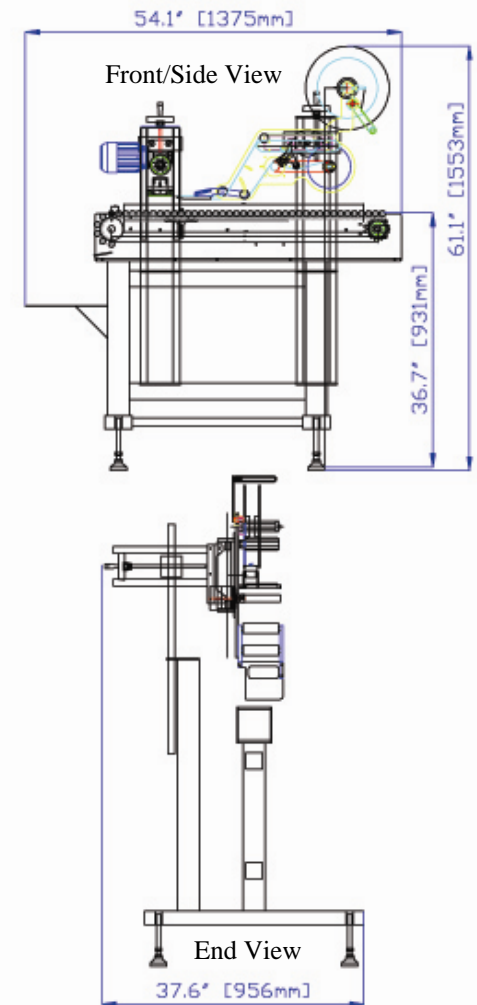

Dimensional Drawing