

- *Stainless Steel Construction*
- *Programmable Controller with Memory Recall (Reduced Set Up Time)*
- *Adjustable Guide Rails*
- *Turn Handle Adjust for Label Applicator Height to Easily Accommodate Varied Product Sizes*
- *Variable Speed Conveyor*
- *Equipped Standard with Ketan K50 Label Applicator*
- *Built In Product Counter*
- *Equipped with Leveling Feet & Casters- Can Be Fixed In Place or Completely Mobile*
- *Apply Labels to the Tops of Various Flat Surfaced Products Such As: Food Tray Packages, Corrugated Cartons, Chipboard Cartons, Round Jars & More!*



Apply labels to the tops of food tray packages & more!



Automatically apply labels to the tops of various types of products

Standard Features & Specifications

- Equipped standard with the "Automatic Label Set" feature for reduced set up time
- Equipped standard with Ketan K50 label applicator
- Capable of handling products with diameters or widths up to 6"
- Maximum conveyor speed of 70 ft/min
- Maximum label dispense speed of 90 ft/min
- K50- Min label width : 3/8" Max label width: 4.25"
- Programmable Controller with LCD display
- Dimensions: please see dimensional drawing
- Completely mobile system or fixed in place
- Equipped standard with adjustable guide rails
- Built in product counter
- Stainless Steel Construction

Options

- Three stage light beacon
- Clear label sensor
- Low label sensor
- Tamp
- Blow Box
- K200 applicator upgrade- increased label width capacity to 6"

Electrical Requirements

115 VAC 50-60Hz (10 amps)

Weight

270 lbs (135 kg)

Environment

32° to 115° F (0° to 46° C)



Excellent Label Placement Accuracy

Ketan Automated Equipment, Inc. offers a wide range of coding, labeling & product handling systems for identification of products in multiple types of industries

As part of the continuing process of development Ketan reserves the right to alter the specifications and other details of its products without notice. Please ask Ketan for the latest details

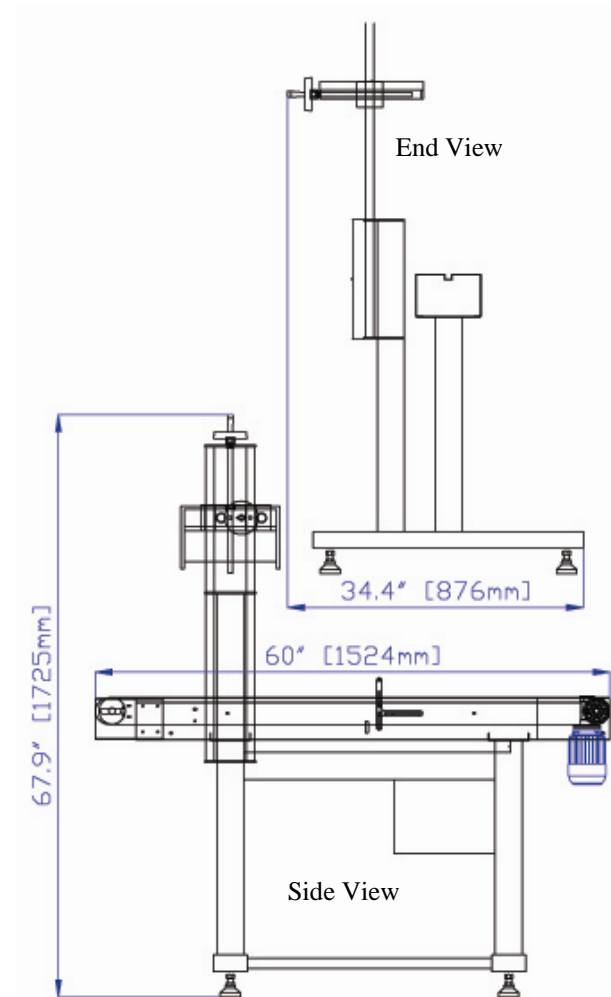

Dimensional Drawing

Ketan Automated Equipment, Inc.

1140 E Locust Street, Suite 100, Ontario, CA 91761

Phone (909) 930-0780 Fax (909) 930-0945

www.ketanautomated.com