

- **Stainless Steel Construction**
- **Equipped Standard with Ketan K-200 Applicators (Up to 6.25" Label Width Capacity)**
- **Equipped Standard with "Automatic Label Set" Feature (reduced set up time)**

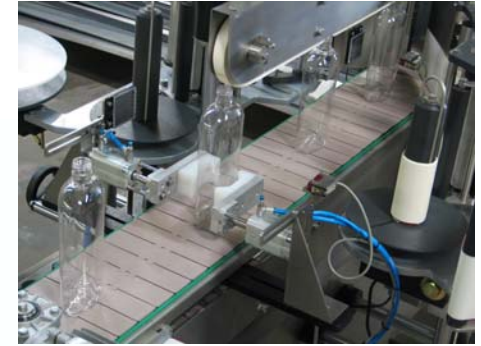

Stepper Pneumatic In Feed Module For Increased Label Placement Accuracy with Oval or Angled Surfaces

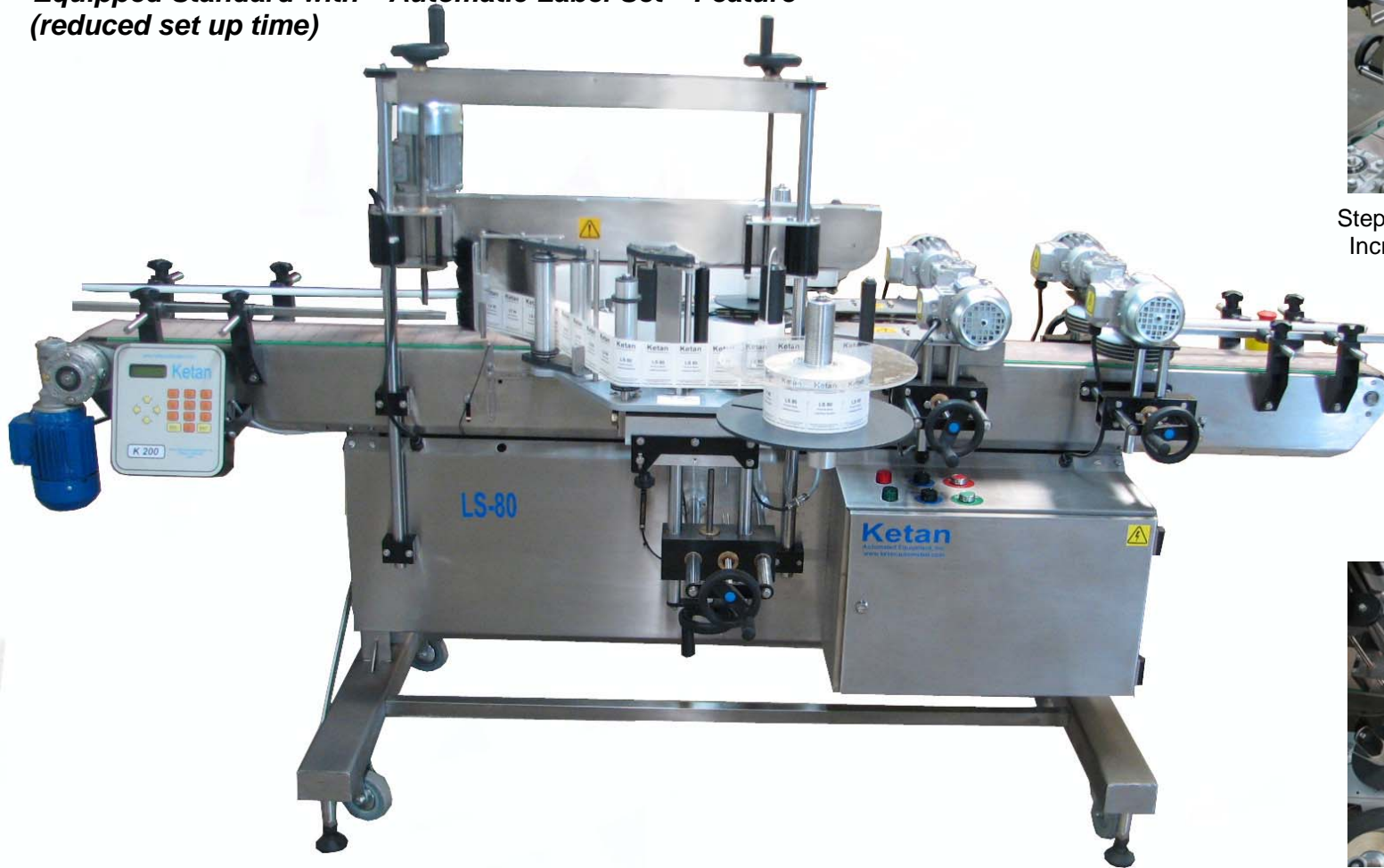

Elliptical Aligner In Feed Module

- **Equipped Standard with Dual Wheel In Feed Spacing Mechanism**
- **Excellent Label Placement Accuracy**
- **Apply Labels to the Front & Back Sides of Flat or Oval Products**

Standard Features & Specifications

- Equipped standard with the “Automatic Label Set” feature for reduced set up time
- Base conveyor, top hold down drive & in feed module are self synchronizing
- Equipped standard with Ketan K 200 label applicators
- Capable of handling products up to 6.5” wide
- Maximum conveyor speed of 70 ft/min
- Increased speed can be obtained– ask Ketan representative for details
- Min label width: 3/8” Max label width: 6.25”
- Equipped standard with X-Y & tilt adjusting label applicator base
- Programmable applicator controllers with LCD display & memory allocation
- Ink Jet or Hot Stamp coder integration- capabilities for printing directly onto label
- Dimensions: please see dimensional drawing
- Completely mobile system or fixed in place
- Equipped standard with adjustable guide rails
- Built in product counters on each controller
- Stainless construction
- Changes or custom designs to accommodate various types of applications can be done– Ask a Ketan representative for details

Options

- Screw drives - Infeed
- K200-S high speed applicators with 16” supply reel
- Elliptical aligner –Infeed
- Saloon door tamp module– label front and both side panels
- Three stage light beacon
- Clear label sensors
- Foam rollers for secondary wipe
- Blow box modules
- Tamp modules



Excellent label placement accuracy Apply labels to various types of flat or oval products

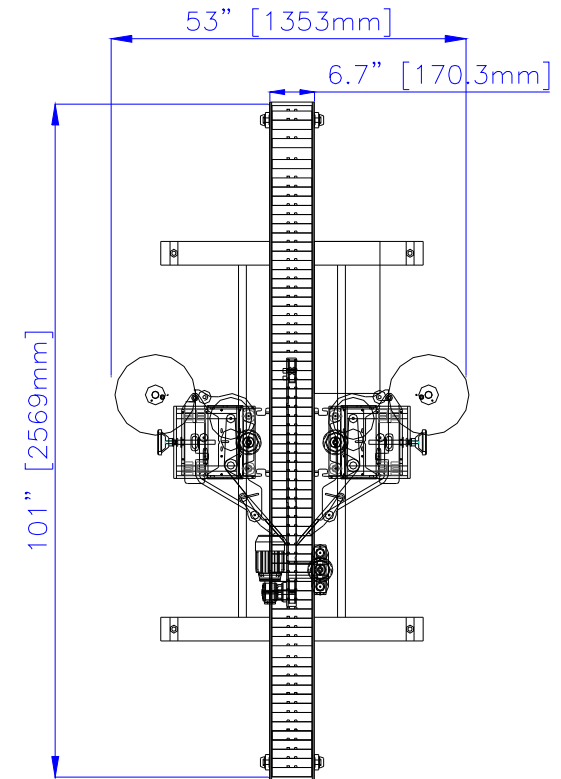

Dimensional Drawing

Electrical Requirements

115 VAC 50-60Hz (10 amps)

Weight

440 lbs (220 kg)

Environment

32° to 115° F (0° to 46° C)

Ketan Automated Equipment, Inc. offers a wide range of coding, labeling & product handling systems for identification of products in multiple types of industries

As part of the continuing process of development Ketan reserves the right to alter the specifications and other details of its products without notice. Please ask Ketan for the latest details

Ketan Automated Equipment, Inc.

1140 E Locust Street, Suite 100, Ontario, CA 91761

Phone (909) 930-0780 Fax (909) 930-0945