

KPA 400

Print & Apply Label Applicator



Programmable Controller
with LCD display



Print & apply labels to various types of products. The Ketan KPA-400 can be configured as a stand alone unit on a t-base stand which can roll up to a case conveyor or other carton conveyance system. Utilizing one of our standard application modules, the KPA 400 would print & apply labels to the corrugated cartons. Product handling systems can also be designed to integrate with the KPA 400 to accommodate various types of applications or products

Examples of some of the various Ketan product handling systems for the KPA 400 printer applicator



Flat carton dispenser—
dispenses cartons from stack one at a time to be labeled prior to erecting carton



System designed to print & apply labels to round tubes



Pic & Place of pouches—
pouches are lifted from stack & placed for KPA-400 to print & apply label



Flat chipboard carton feeding system—
dispenses one carton at a time from feeder magazine & conveys cartons under KPA 400 for label placement

Standard Features & Specifications

- Equipped standard with programmable controller with LCD display
- Up to 32 memory storage allocations
- Standard outputs: tamp, tamp-blow, blow, smart tamp, air assist, low label, low ribbon, printer ready & error
- Standard inputs: product detector, low label sensor & engine interface
- Standard print engine interface: Zebra & Sato print engines
- Standard unit is equipped with 4" x 6" tamp module
- Programmable dispense cycle-normal & reverse
- Programmable air assist, tamp dwell, blow, tamp-blow & product delay
- Equipped standard with tamp module, u-arm, KPA 400 chassis, programmable controller with LCD display & standard cables

Electrical Requirements

115 or 220 VAC 50-60Hz (10 amps)

Air

80 lbs, 5 cfm, clean, dry air

Weight

76 lbs (38kg)

(dependent on print engine selected)

Environment

32° to 115° F (0° to 46° C)

Options

- T-base stand
- Product detector
- Low label sensor
- Three stage alarm beacon
- Case conveyor with adjustable guide rails
- Various application modules:
 - Tamp/blow
 - Blow box
 - Corner wrap
 - Tamp with various size pads
 - Secondary wipe
 - Wipe roll
- Zebra & Sato print engines
- Zebra & Sato print engine accessories & communication upgrades
- Label verification & data collection systems or components (Scanners, data collection hardware & software)
- Custom mechanical or software integration
- Custom systems design
- Flat carton dispensing system
- Ketan PL 400 pallet labeling system

***Ketan has developed many types of integrated systems for the KPA 400. Should you have an application requiring product handling or other types of integration, please contact a Ketan representative to discuss details*

Ketan Automated Equipment, Inc. offers a wide range of coding, labeling & product handling systems for identification of products in multiple types of industries

As part of the continuing process of development Ketan reserves the right to alter the specifications and other details of its products without notice. Please ask Ketan for the latest details

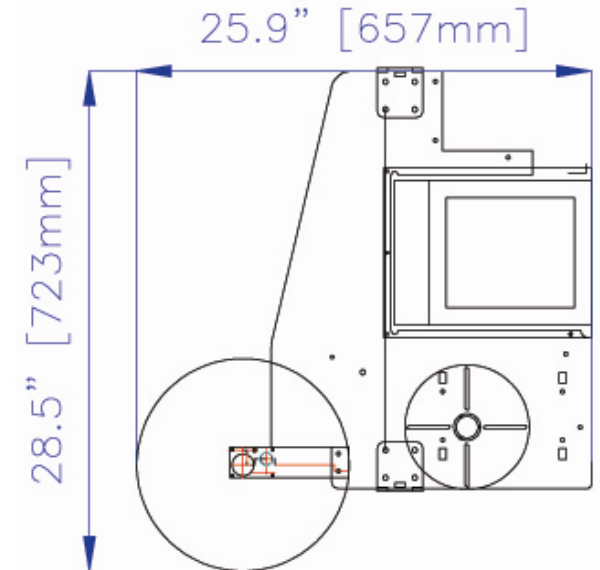
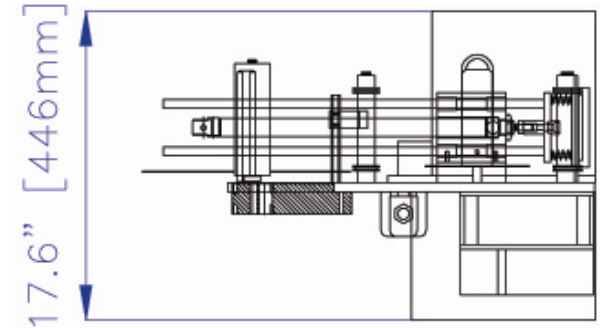

Dimensional Drawing

Ketan Automated Equipment, Inc.

1140 E Locust Street, Suite 100, Ontario, CA 91761

Phone (909) 930-0780 Fax (909) 930-0945