

Apply labels to the tops, sides & bottoms
of various types of products

- Low cost label applicator with higher end capabilities
- Apply labels up to 4.25" in width by 16" in length
- Application speeds up to 90 ft/min
- Programmable controller with LCD display
- Store multiple label parameters and recall (reduce set up time)
- Excellent label placement accuracy
- Password lockout features, reducing operator error

Standard Features & Specifications

- Label size capacity
 - Min: 1/2" W x 1/2" L (13 mm x 13 mm)
 - Max: 4.25" W x 16" L (108 mm x 406 mm)
- Label placement accuracy
 - +/- 1/32" (1mm) (labels produced to spec & product handling controlled)
- Web speed capability
 - Up to 90 feet/min (30 M/min)
- Label roll specifications
 - 12" maximum outside roll diameter (304 mm)
 - Label wound on a 3" (76 mm) inside diameter core
 - Die cut waste removed with a minimum of 1/8" (3 mm) separation between labels in web flow direction
- Dimensions (see dimensional drawing)
- Storage capacity for 20 individual labels parameters
- Programmable, remotely mountable controller with LCD display
- Equipped standard with a wipe on module & brush attachment
- Programmable label stop, product delay, tamp/blow dwell, air assist delay, web speed, coder dwell, coder signal delay & tamp/blow label dispense (pre or post apply)

Standard Inputs

- Product detector
- Shaft Encoder
- Dual Photocell

Standard Outputs

- Alarm (missing label, low label, label ready)
- Tamp/blow
- Air assist
- Ink jet coder print go signal - print onto labels with the integration of an ink jet coder

Options

- T-base stand
- Clear label sensor
- Low label sensor
- Three stage light beacon
- Shaft encoder
- Product detector
- Blow box module
- Tamp module

Electrical Requirements

115 VAC 50-60Hz (5 amps)

Weight

40 lbs (20 kg)

Environment

32° to 115° F (0° to 46° C)

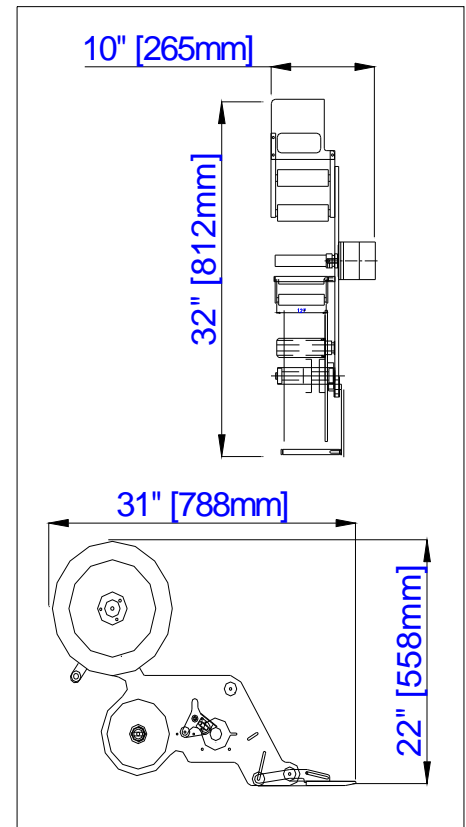

Dimensional Drawing

Ketan is continually developing products high in quality & capabilities in order to offer a high end solution at a cost effective price. The Ketan K 50 Label Applicator is a direct result of our R&D process created in order to offer "more for less". The K 50 offers reliability with high end capabilities & adds value to the end users production environment at a very low price

Ketan Automated Equipment, Inc. offers a wide range of coding, labeling & product handling systems for identification of products in multiple types of industries

As part of the continuing process of development Ketan reserves the right to alter the specifications and other details of its products without notice. Please ask Ketan for the latest details

Ketan Automated Equipment, Inc.

1140 E Locust Street, Suite 100, Ontario, CA 91761

Phone (909) 930-0780 Fax (909) 930-0945

www.ketanautomated.com