



Blow Module



Tamp Module



Wipe Module

- ***Modular, higher end labeling at an affordable price !***
 - ***Apply labels up to 6.5" in width by 18" in length***
 - ***Application speeds up to 120 ft/min***
 - ***Programmable controller with LCD display***
 - ***Store multiple label parameters and recall (reduce set up time)***
 - ***Excellent label placement accuracy***
 - ***Password lockout features, reducing operator error***
 - ***Built in product counter***
 - ***"Automatic Label Calibration Feature" (reduces set up time)***

Standard Features & Specifications

- Label size capacity
Min: 1/2" W x 1/2" L (13 mm x 13 mm)
Max: 6.5" W x 18" L (159 mm x 457 mm)
- Label placement accuracy
+/- 1/32" (1mm) (labels produced to spec & product handling controlled)
- Web speed capability
K200- 40meters/min 120feet/min
- Label roll specifications
K200- 12" maximum outside roll diameter (304 mm)
Label wound on a 3" (76 mm) inside diameter core
Die cut waste removed with a minimum of 1/8" (3 mm) separation between labels in web flow direction
- Dimensions (see dimensional drawing)
- Storage capacity for 20 individual labels parameters
- Programmable, mountable controller with LCD display
- Equipped standard with a wipe on module & brush attachment
- Programmable label stop, product delay, tamp/blow dwell, air assist delay, web speed, coder dwell, coder signal delay & tamp/blow label dispense (pre or post apply)

Standard Inputs

- Product detector
- Shaft Encoder
- Dual Photocell

Options

- T-base stand
- Clear label sensor
- Low label sensor
- Three stage light beacon
- Shaft encoder
- Product detector
- Blow box module
- Tamp or tamp/blow module

Electrical Requirements

115 VAC 50-60Hz (5 amps)

Weight

58 lbs (29 kg)

Environment

32° to 115° F (0° to 46° C)

Standard Outputs

- Alarm (missing label, low label, label ready)
- Tamp/blow
- Air assist
- Ink jet coder print go signal - print onto labels with the integration of an ink jet coder

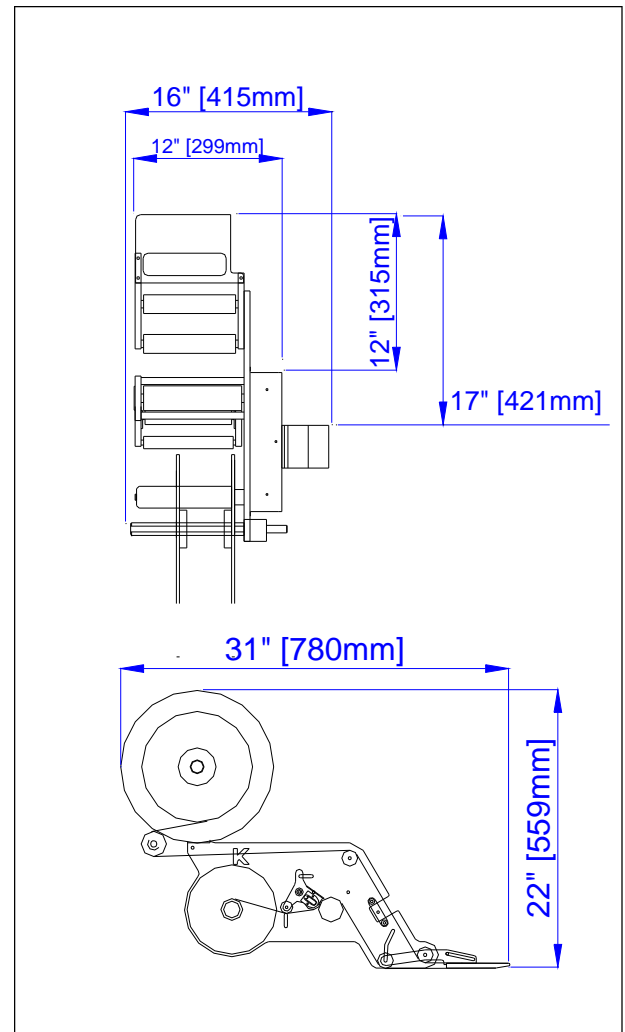

Dimensional Drawing

Ketan is continually developing products high in quality & capabilities in order to offer a higher end solution at a cost effective price. The Ketan K 200 Label Applicator is a direct result of our R&D process created in order to offer "more for less". The K 200 has been developed to offer a cost effective solution for applications requiring higher end capabilities without compromising reliability, modularity or competitive capabilities.

Ketan Automated Equipment, Inc. offers a wide range of coding, labeling & product handling systems for identification of products in multiple types of industries

As part of the continuing process of development Ketan reserves the right to alter the specifications and other details of its products without notice. Please ask Ketan for the latest details

Ketan Automated Equipment, Inc.

1660 South Grove Ave, Bldg B, Ontario, CA 91761

Phone (909) 930-0780 Fax (909) 930-0945

www.ketanautomated.com